



800 SERIES OVEN RANGES

711 mm Fan Forced Oven

PE2S24G28FF - Electric

- High performance easy to clean 2 kW solid hot plates
- Stainless steel fascia and sides, spill zone and drip trays for ease of cleaning
- Flexible, modular cook top design enables many combinations of elements and griddle
- Fan forced oven in gastronorm compatible sizes
- Ovens are fully insulated vitreous enamel for even heat and easy cleaning
- Heavy duty welded steel body for rigidity and durability

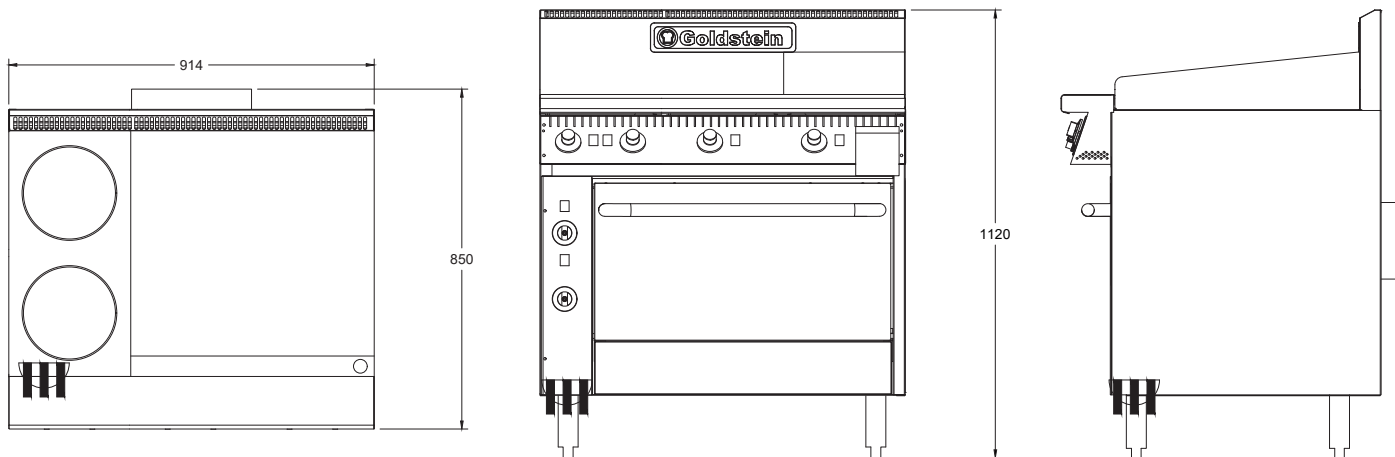

PE2S24G28FF

SPECIFICATIONS

Dimensions (WxDxH)	914 x 850* x 1120 mm	 3 Phase
Working height	914 mm	Weight 230 kg
Oven Size	711 x 525 x 355 mm	Packed 0.5 m ³
Solid Plates	2	Electric Connection 3 phase, 415V + N + E
Griddle size (WxH)	610 x 12 mm	Rating 23 kW

Australia's premier food service
equipment manufacturer

goldstein.com.au

211-217 Woodpark Road, Smithfield NSW 2164
1800 013 123 | +61 2 9604 7333

 **MIDDLEBY AUSTRALIA**

