



# 800 SERIES OVEN RANGES

## 505 mm Static Oven

### PE2SI2G20 - Electric

- High performance easy to clean 2 kW solid hot plates
- Stainless steel fascia and sides, spill zone and drip trays for ease of cleaning
- Flexible, modular cooktop design enables many combinations of elements and griddle
- Static oven in gastronorm compatible sizes
- Ovens are fully insulated vitreous enamel for even heat and easy cleaning
- Heavy duty welded steel body for rigidity and durability

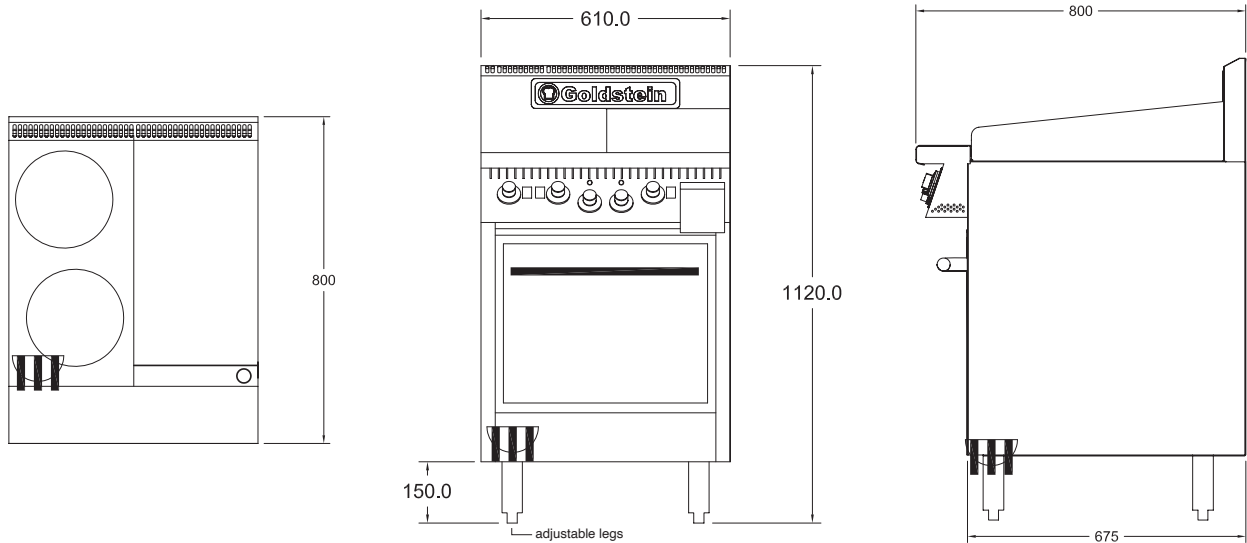

### PE2SI2G20

#### SPECIFICATIONS

<b>Dimensions (WxDxH)</b>	610 x 800 x 1120 mm
<b>Working height</b>	914 mm
<b>Solid Plates</b>	2
<b>Griddle size (WxH)</b>	305 x 12 mm

 3 Phase

<b>Weight</b>	129 kg
<b>Packed</b>	0.5 m <sup>3</sup>
<b>Electric Connection</b>	3 phase, 415V + N + E
<b>Rating</b>	15.5 kW

Australia's premier food service equipment manufacturer

 **MIDDLEBY AUSTRALIA**

[goldstein.com.au](http://goldstein.com.au)

211-217 Woodpark Road, Smithfield NSW 2164  
1800 013 123 | +61 2 9604 7333

